

Chain Hoist

FEATURES AND BENEFITS

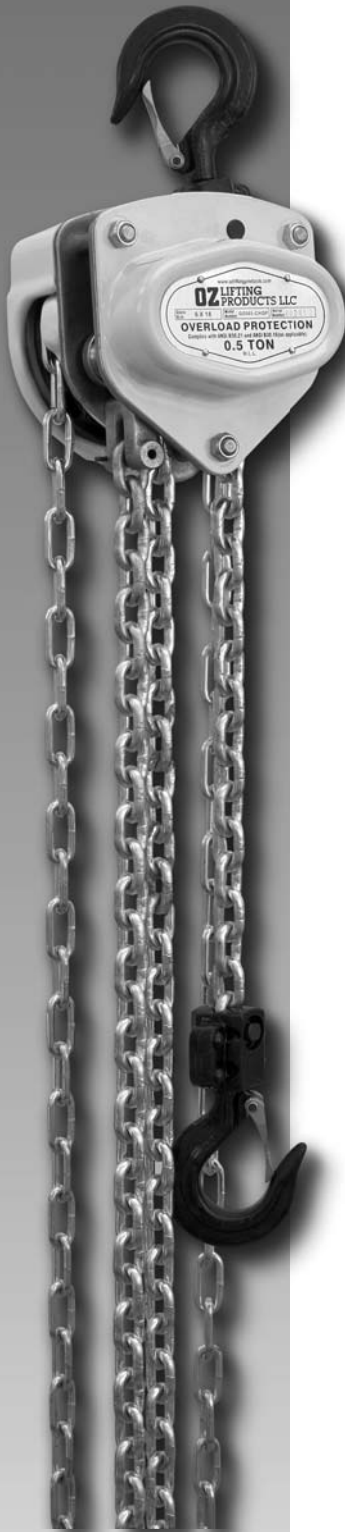

Overload Protection

This is standard on all hoists and is factory set. The overload is integral with the hoist and prevents the operator from overloading the hoist. When activated, the overload will not allow hoist operation. When the overload is activated, lower the load, if lifting, or release the load, if pulling. Then select a larger capacity hoist, or consult a lifting specialist for another means of operation.

Minimal Load Lifting Effort

These hoists require **20% - 30% less effort** than the competition. Lift heavy loads with ease. Ideal for frequent lifting/pulling applications.

Fully Enclosed Gearing

This protects the gears from contamination and debris.

All Steel Construction

These hoists are strong, durable and rugged, providing a long and dependable service life.

Malleable Hooks with Cast Steel Safety Latches

These hooks open when overloaded, thus providing the operator with a hook load reference point. Each heavy duty cast steel safety latch has a bolt and lock nut connection rather than roller pins used by most competitors. This feature facilitates changing latches in the field.

Weather Proof Load Holding Brake

Both hoists have a protected Weston Brake which holds the load during the entire operation. The hoists are also equipped with a unique twin pawl design.

All Gears and Shafts Run on Roller Bearings

This feature provides smooth controlled operation as well as maintenance free lubrication.

Stainless Steel Riveted ID Tags

These tags will not rust and will maintain clear distinct information for easy identification.

Safety Yellow Powder Coating

This process provides a long lasting finish in hostile environments.

Maintenance

Hoists can be quickly disassembled for fast and easy maintenance.

Certification

Each hoist is load tested and comes with a serial number and test certificate dedicated to each hoist. This provides complete traceability throughout the manufacturing process.



Chain Hoist with overload protection

FEATURES AND BENEFITS

Fully Machined Lift Wheel - This feature perfectly accepts the chain allowing for a smooth long lasting operation.

Totally Enclosed Gearing - This design protects gears from contamination and debris.

Thrust Bearing on Lower Hook - Allows easy rotation of load while suspended & prevents load chain twisting.

Lifting or Pulling - This hand hoist can be used for lifting or pulling which makes for a more flexible and versatile tool.

Unique Hand Wheel Design - This feature enables the hand chain to successfully feed directly into the wheel sprocket from many directions and angles. The operator can work the hoist, while standing above or to the side of the load, without jamming the hand chain.

Low Headroom - Provides maximum lift by minimizing space taken up by the hoist, making it ideal in restricted space applications.

Electro Zinc Plated Hand Chain - Provides a durable finish.

Tempered Load Chain - Provides a long, reliable lifting life.

DIMENSIONS (0.5, 1, 1.5, 2, 3, 5 and 10 tons)

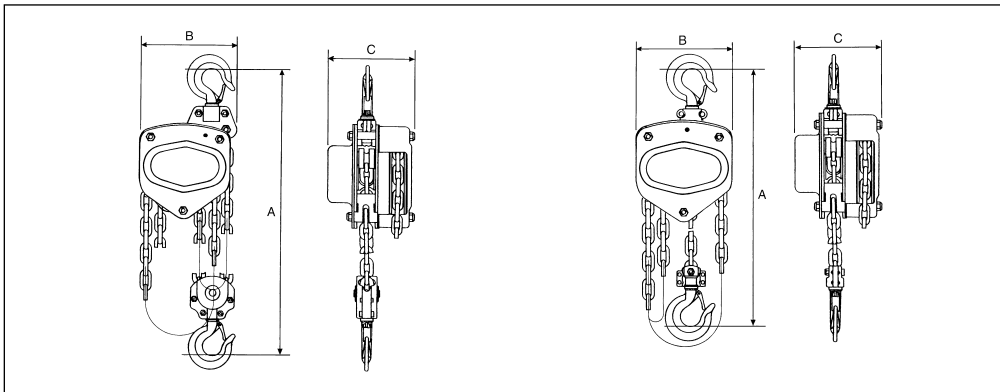

SPECIFICATIONS (0.5, 1, 1.5, 2, 3, 5 and 10 tons)

Product Code	OZ005CHOP	OZ010CHOP	OZ015CHOP	OZ020CHOP	OZ030CHOP	OZ050CHOP	OZ100CHOP
Safe Working Load (tons)	.5 (t)	1 (t)	1.5 (t)	2 (t)	3 (t)	5 (t)	10 (t)
Falls of Chain	1	1	1	1	2	2	4
Effort to Lift S.W.L (pounds)	50.10 (lbs)	66.14 (lbs)	70.46 (lbs)	77.16 (lbs)	59.52 (lbs)	90.39 (lbs)	85.98 (lbs)
Loadchain Diameter (millimeters)	6 (mm)	6 (mm)	8 (mm)	8 (mm)	8 (mm)	10 (mm)	10 (mm)
Dimensional Information (inches)	A	10.62 (in)	12.48 (in)	15.70 (in)	16.29 (in)	18.30 (in)	25.03 (in)
	B	5.00 (in)	6.22 (in)	7.36 (in)	7.36 (in)	8.26 (in)	9.96 (in)
	C	5.15 (in)	5.51 (in)	6.33 (in)	6.33 (in)	6.33 (in)	6.33 (in)
Hook-opening, upper & lower (inches)	1.18 (in)	1.10 (in)	1.41 (in)	1.31 (in)	1.57 (in)	1.96 (in)	2.51 (in)
Net Weight of Head Only (pounds)	12 (lbs)	17 (lbs)	25 (lbs)	29 (lbs)	49 (lbs)	60 (lbs)	113 (lbs)

